

DrillLine

DRILLFORCE MEISTER

www.tungaloy.com

Tungaloy Report No. 509-G

DRILLFORCE-MEISTER

Head-changeable drill

for drilling large holes



Member IMC Group
Tungaloy



ACCELERATED MACHINING



DrillLine

DRILL FORCE MEISTER
TUNGALOY

TUNG FORCE DRILL
ACCELERATED MACHINING



Unique clamping concept and two effective cutting edges on the drill head provide excellent hole quality and high productivity

www.tungaloy.com

Improves productivity and reliability in heavy drilling with unique drill head and clamping concept

Two effective cutting edges

- The drill head with two effective cutting edges provides high productivity and reliability

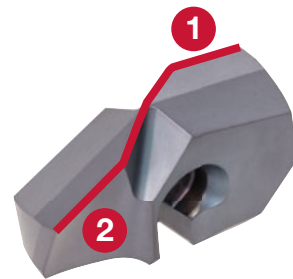

Optimized drill body

- The drill body has an optimized flute design for smooth chip evacuation and enhanced stiffness



Unique clamping system

Easy and quick yet rigid and reliable clamping method for excellent hole quality and long tool life

- The drill head change is possible without removing the drill body from the tool holder or the spindle, eliminating re-adjustments
- Asymmetric shaped drill head not only secures stability in heavy machining but also error-proofs drill head installation
- The drill body has a wide supporting area for the drill head for rigid insert clamping
- By replacing the head screw regularly, the drill body can be used for an even longer period



High productivity

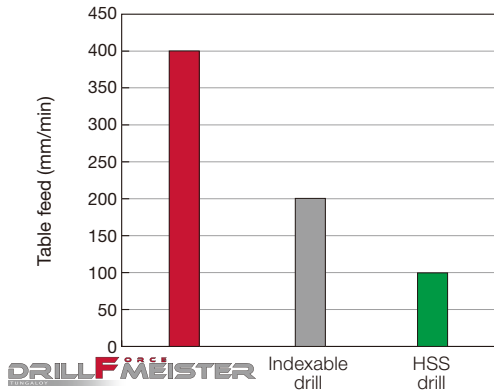

Drill : $\phi 33$ mm, L/D = 5
 Workpiece material : S55C / C55

	Cutting speed Vc (m/min)	Feed f (mm/rev)	Feed speed Vf (mm/min)
DRILLFMEISTER	100	0.4	430
Indexable drill	150	0.15	240
HSS drill	20	0.4	85

AH725, a highly reliable PVD grade

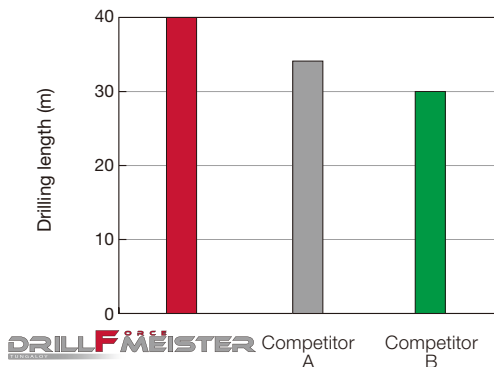

Drill : $\phi 26$ mm
 Workpiece material : S55C / C55
 Cutting speed : Vc = 100 m/min
 Feed : f = 0.35 mm/rev
 Drilling depth : H = 120 mm

AH725 achieves smooth and flat coating surface to improve resistance to build-up edge and chipping, thus extending tool life in heavy machining.

An smart combination of optimized edge preparation and dedicated PVD grade extends tool life in heavy drilling

AH725, a highly reliable PVD grade

AH725 **PREMIUMTEC**

Improved coating adhesion

Sub-micron grain carbide substrate with superior toughness and resistance to plastic-deformation

Super-flash coating:
Eliminates droplets on the surface

Conventional

➔

AH725

Optimized edge preparation

- Enlarged images of the edges before use

The cutting edge is honed to enhance coating adhesion

No coating delamination

Honed edge

DRILLFMEISTER

Coating is delaminated

Chamfered edge
Competitor

CUTTING PERFORMANCE

Hole size



The hole size is stable in various cutting conditions and materials

Drill : TIS350F40-5 (ø35 mm)
 Head : SMP350
 Grade : AH725
 Workpiece material : SCM440 / 42CrMo4, SUS304 / X5CrNi18-9
 Cutting speed : Vc = 80 - 120 m/min (SCM440 / 42CrMo4)
 Vc = 40 - 70 m/min (SUS304 / X5CrNi18-9)
 Feed : f = 0.3 - 0.5 mm/rev (SCM440 / 42CrMo4)
 f = 0.2 - 0.3 mm/rev (SUS304 / X5CrNi18-9)
 Drilling depth : H = 100 mm
 Machine : Horizontal M/C (BT50)
 Coolant : Wet (Internal)

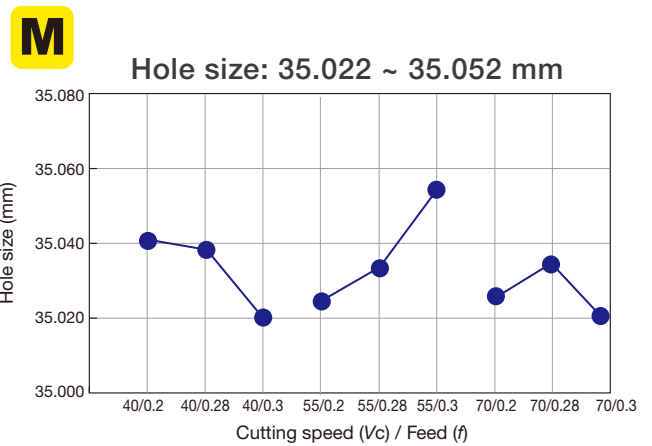
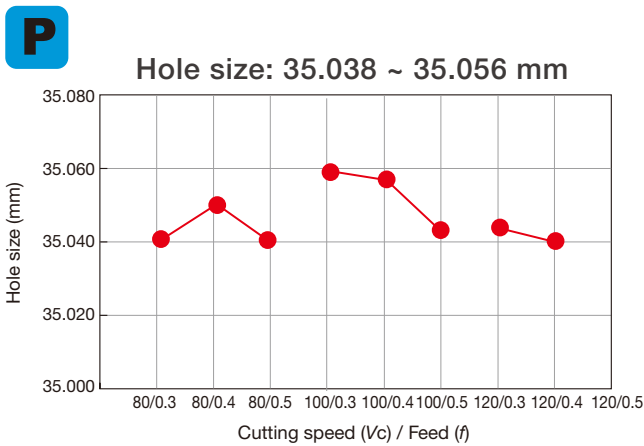

Chip control

DrillForceMeister provides good chip control even in drilling low carbon steel

0.2			
0.3			
0.4			
Feed: f (mm/rev)	DRILLFORCE MEISTER	Competitor A	Competitor B

Drill : TIS260F32-5 (ø26 mm)
 Head : SMP260
 Grade : AH725
 Workpiece material : SS400 / E275A
 Cutting speed : Vc = 100 m/min
 Feed : f = 0.2 - 0.4 mm/rev
 Drilling depth : H = 100 mm
 Machine : Horizontal M/C (BT50)
 Coolant : Wet (Internal)

TIS L/D=3

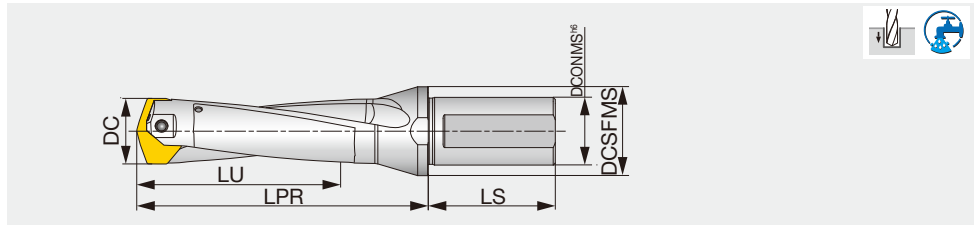

Designation	DC	DCONMS	DCSFMS	LU	LPR	LS	Pocket size	Head
TIS260F32-3	26 - 26.9	32	40	82.7	117	60	26	SMP26*
TIS270F32-3	27 - 27.9	32	40	85.9	120	60	27	SMP27*
TIS280F32-3	28 - 28.9	32	40	89.1	128.4	60	28	SMP28*
TIS290F32-3	29 - 29.9	32	40	92.3	131.4	60	29	SMP29*
TIS300F32-3	30 - 30.9	32	42	95.5	134.7	60	30	SMP30*
TIS310F32-3	31 - 31.9	32	42	98.6	137.7	60	31	SMP31*
TIS320F40-3	32 - 32.9	40	48	101.8	143	68	32	SMP32*
TIS330F40-3	33 - 33.9	40	48	105	146	68	33	SMP33*
TIS340F40-3	34 - 34.9	40	48	108.2	149	68	34	SMP34*
TIS350F40-3	35 - 35.9	40	48	111.4	152.4	68	35	SMP35*
TIS360F40-3	36 - 36.9	40	48	114.6	155.4	68	36	SMP36*
TIS370F40-3	37 - 37.9	40	48	117.7	158.4	68	37	SMP37*
TIS380F40-3	38 - 38.9	40	50	120.9	166.9	68	38	SMP38*
TIS390F40-3	39 - 39.9	40	50	124.1	169.9	68	39	SMP39*
TIS400F40-3	40 - 41	40	50	127.3	172.9	68	40	SMP40*

Tool diameter	Hole diameter tolerance*
ø26 - ø29.9	+0.05 / 0
ø30 - ø41	+0.06 / 0

SPARE PARTS



Designation	Clamping screw	Wrench	
		Torx Bit	Grip
TIS260F32-*	TS50230D3	BLDT20/S7	H-TB2W
TIS270F32-*	TS50230D3	BLDT20/S7	H-TB2W
TIS280F32-*	TS50250D35	BLDT25/S7	H-TB2W
TIS290F32-*	TS50250D35	BLDT25/S7	H-TB2W
TIS300F32-*	TS60265D4	BLDT25/S7	H-TB2W
TIS310F32-*	TS60265D4	BLDT25/S7	H-TB2W
TIS320F40-*	TS60285D42	BLDT25/S7	H-TB2W
TIS330F40-*	TS60285D42	BLDT25/S7	H-TB2W
TIS340F40-*	TS60285D42	BLDT25/S7	H-TB2W
TIS350F40-*	TS60320D5	BLDT25/S7	H-TB2W
TIS360F40-*	TS60320D5	BLDT25/S7	H-TB2W
TIS370F40-*	TS60320D5	BLDT25/S7	H-TB2W
TIS380F40-*	TS80340D6	BLDT25/S7	H-TB2W
TIS390F40-*	TS80340D6	BLDT25/S7	H-TB2W
TIS400F40-*	TS80340D6	BLDT25/S7	H-TB2W

TIS L/D=5

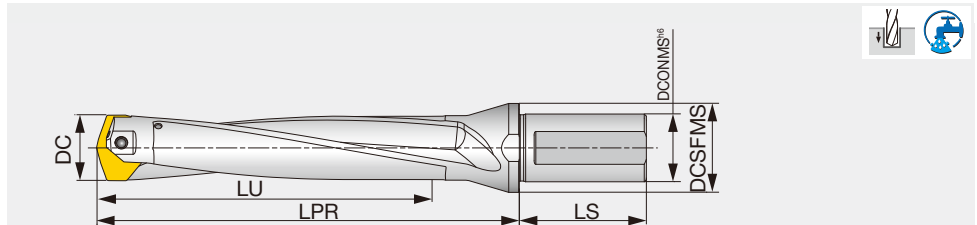

Designation	DC	DCONMS	DCSFMS	LU	LPR	LS	Pocket size	Head
TIS260F32-5	26 - 26.9	32	40	134.7	169	60	26	SMP26*
TIS270F32-5	27 - 27.9	32	40	139.9	174	60	27	SMP27*
TIS280F32-5	28 - 28.9	32	40	145.1	184.4	60	28	SMP28*
TIS290F32-5	29 - 29.9	32	40	150.3	189.4	60	29	SMP29*
TIS300F32-5	30 - 30.9	32	42	155.5	194.7	60	30	SMP30*
TIS310F32-5	31 - 31.9	32	42	160.6	199.7	60	31	SMP31*
TIS320F40-5	32 - 32.9	40	48	165.8	207	68	32	SMP32*
TIS330F40-5	33 - 33.9	40	48	171	212	68	33	SMP33*
TIS340F40-5	34 - 34.9	40	48	176.2	217	68	34	SMP34*
TIS350F40-5	35 - 35.9	40	48	181.4	222.4	68	35	SMP35*
TIS360F40-5	36 - 36.9	40	48	186.6	227.4	68	36	SMP36*
TIS370F40-5	37 - 37.9	40	48	191.7	232.4	68	37	SMP37*
TIS380F40-5	38 - 38.9	40	50	196.9	242.9	68	38	SMP38*
TIS390F40-5	39 - 39.9	40	50	202.1	247.9	68	39	SMP39*
TIS400F40-5	40 - 41	40	50	207.3	252.9	68	40	SMP40*

Tool diameter	Hole diameter tolerance*
ø26 - ø29.9	+0.08 / 0
ø30 - ø41	+0.09 / 0

SPARE PARTS



Designation	Clamping screw	Wrench	
		Torx Bit	Grip
TIS260F32-*	TS50230D3	BLDT20/S7	H-TB2W
TIS270F32-*	TS50230D3	BLDT20/S7	H-TB2W
TIS280F32-*	TS50250D35	BLDT25/S7	H-TB2W
TIS290F32-*	TS50250D35	BLDT25/S7	H-TB2W
TIS300F32-*	TS60265D4	BLDT25/S7	H-TB2W
TIS310F32-*	TS60265D4	BLDT25/S7	H-TB2W
TIS320F40-*	TS60285D42	BLDT25/S7	H-TB2W
TIS330F40-*	TS60285D42	BLDT25/S7	H-TB2W
TIS340F40-*	TS60285D42	BLDT25/S7	H-TB2W
TIS350F40-*	TS60320D5	BLDT25/S7	H-TB2W
TIS360F40-*	TS60320D5	BLDT25/S7	H-TB2W
TIS370F40-*	TS60320D5	BLDT25/S7	H-TB2W
TIS380F40-*	TS80340D6	BLDT25/S7	H-TB2W
TIS390F40-*	TS80340D6	BLDT25/S7	H-TB2W
TIS400F40-*	TS80340D6	BLDT25/S7	H-TB2W

DRILL HEAD

SMP

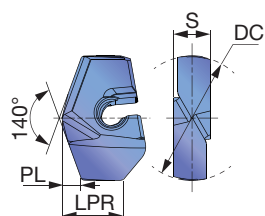
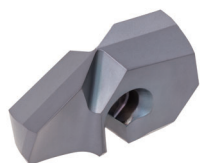

Designation	DC	AH725	S	LPR	PL	Pocket size	Body	Designation	DC	AH725	S	LPR	PL	Pocket size	Body
SMP260	26	●	7.5	11.6	4.73	26	TIS260F32-*	SMP361	36.1	●	10	16.1	6.57	36	TIS360F40-*
SMP261	26.1	●	7.5	11.6	4.75	26	TIS260F32-*	SMP365	36.5	●	10	16.1	6.64	36	TIS360F40-*
SMP265	26.5	●	7.5	11.6	4.82	26	TIS260F32-*	SMP366	36.6	●	10	16.1	6.66	36	TIS360F40-*
SMP267	26.7	●	7.5	11.6	4.86	26	TIS260F32-*	SMP370	37	●	10	15.7	6.73	37	TIS370F40-*
SMP270	27	●	7.5	11.1	4.91	27	TIS270F32-*	SMP371	37.1	●	10	15.7	6.75	37	TIS370F40-*
SMP271	27.1	●	7.5	11.1	4.93	27	TIS270F32-*	SMP375	37.5	●	10	15.7	6.82	37	TIS370F40-*
SMP272	27.2	●	7.5	11.1	4.95	27	TIS270F32-*	SMP380	38	●	10.5	17	6.92	38	TIS380F40-*
SMP275	27.5	●	7.5	11.1	5	27	TIS270F32-*	SMP381	38.1	●	10.5	17	6.93	38	TIS380F40-*
SMP280	28	●	8	11.7	5.1	28	TIS280F32-*	SMP385	38.5	●	10.5	17	7.01	38	TIS380F40-*
SMP281	28.1	●	8	11.7	5.11	28	TIS280F32-*	SMP388	38.8	●	10.5	17	7.06	38	TIS380F40-*
SMP285	28.5	●	8	11.7	5.19	28	TIS280F32-*	SMP390	39	●	10.5	16.6	7.1	39	TIS390F40-*
SMP286	28.6	●	8	11.7	5.2	28	TIS280F32-*	SMP391	39.1	●	10.5	16.6	7.12	39	TIS390F40-*
SMP290	29	●	8	11.3	5.28	29	TIS290F32-*	SMP395	39.5	●	10.5	16.6	7.19	39	TIS390F40-*
SMP291	29.1	●	8	11.3	5.3	29	TIS290F32-*	SMP397	39.7	●	10.5	16.6	7.22	39	TIS390F40-*
SMP295	29.5	●	8	11.3	5.37	29	TIS290F32-*	SMP398	39.8	●	10.5	16.6	7.24	39	TIS390F40-*
SMP296	29.6	●	8	11.3	5.39	29	TIS290F32-*	SMP400	40	●	10.5	16.2	7.28	40	TIS400F40-*
SMP300	30	●	8.5	14.1	5.46	30	TIS300F32-*	SMP401	40.1	●	10.5	16.2	7.3	40	TIS400F40-*
SMP301	30.1	●	8.5	14.1	5.48	30	TIS300F32-*	SMP405	40.5	●	10.5	16.2	7.37	40	TIS400F40-*
SMP302	30.2	●	8.5	14.1	5.5	30	TIS300F32-*	SMP410	41	●	10.5	16.2	7.46	40	TIS400F40-*
SMP303	30.3	●	8.5	14.1	5.51	30	TIS300F32-*								
SMP305	30.5	●	8.5	14.1	5.55	30	TIS300F32-*								
SMP308	30.8	●	8.5	14.1	5.61	30	TIS300F32-*								
SMP310	31	●	8.5	13.7	5.64	31	TIS310F32-*								
SMP311	31.1	●	8.5	13.7	5.66	31	TIS310F32-*								
SMP315	31.5	●	8.5	13.7	5.73	31	TIS310F32-*								
SMP318	31.8	●	8.5	13.7	5.79	31	TIS310F32-*								
SMP320	32	●	9	14.5	5.82	32	TIS320F40-*								
SMP321	32.1	●	9	14.5	5.84	32	TIS320F40-*								
SMP325	32.5	●	9	14.5	5.91	32	TIS320F40-*								
SMP328	32.8	●	9	14.5	5.97	32	TIS320F40-*								
SMP330	33	●	9	14.1	6.01	33	TIS330F40-*								
SMP331	33.1	●	9	14.1	6.02	33	TIS330F40-*								
SMP333	33.3	●	9	14.1	6.06	33	TIS330F40-*								
SMP335	33.5	●	9	14.1	6.1	33	TIS330F40-*								
SMP340	34	●	9	13.7	6.19	34	TIS340F40-*								
SMP341	34.1	●	9	13.7	6.21	34	TIS340F40-*								
SMP345	34.5	●	9	13.7	6.28	34	TIS340F40-*								
SMP349	34.9	●	9	13.7	6.35	34	TIS340F40-*								
SMP350	35	●	10	16.6	6.37	35	TIS350F40-*								
SMP351	35.1	●	10	16.6	6.39	35	TIS350F40-*								
SMP355	35.5	●	10	16.6	6.46	35	TIS350F40-*								
SMP360	36	●	10	16.1	6.55	36	TIS360F40-*								

Tool diameter	Head diameter tolerance
ø26 - ø29.9	+0.014 / -0.015
ø30 - ø41	+0.014 / -0.02

Package quantity = 1 pc
●: Line-up

STANDARD CUTTING CONDITIONS

ISO	Workpiece materials	Cutting speed Vc (m/min)	Feed: f (mm/rev)		
			øDc (mm)		
			26 - 29.9	30.0 - 35.9	36.0 - 41.0
P	Low carbon steel (C15, C20, etc.)	80 - 140	0.2 - 0.5	0.2 - 0.5	0.2 - 0.55
	Carbon steel and alloy steel (S55C / C55, SCM440 / 42CrMo4, etc.)	80 - 130	0.2 - 0.5	0.2 - 0.5	0.2 - 0.55
	Prehardend steel (NAK80, PX5, etc.)	50 - 100	0.2 - 0.5	0.2 - 0.5	0.2 - 0.55
M	Stainless steel (SUS304 / X5CrNi18-9, SUS316 / X5CrNiMo17-12-3, etc.)	40 - 80	0.15 - 0.3	0.15 - 0.3	0.2 - 0.35
K	Grey cast iron (FC250 / 250, FC300 / 300, etc.)	80 - 180	0.25 - 0.55	0.25 - 0.55	0.3 - 0.6
	Ductile cast iron (400-15, 600-3, etc.)	80 - 140	0.25 - 0.55	0.25 - 0.55	0.3 - 0.6
N	Non ferrous materials	100 - 200	0.4 - 0.6	0.4 - 0.6	0.5 - 0.7
S	Heat-resistant alloys (Inconel718, etc.)	20 - 50	0.1 - 0.2	0.1 - 0.2	0.1 - 0.25
	Titanium alloys (Ti-6Al-4V, etc.)	20 - 50	0.1 - 0.2	0.1 - 0.2	0.1 - 0.25
H	Hardened materials	20 - 60	0.1 - 0.2	0.1 - 0.2	0.1 - 0.25

RECOMMENDED COOLANT PRESSURE AND VOLUME

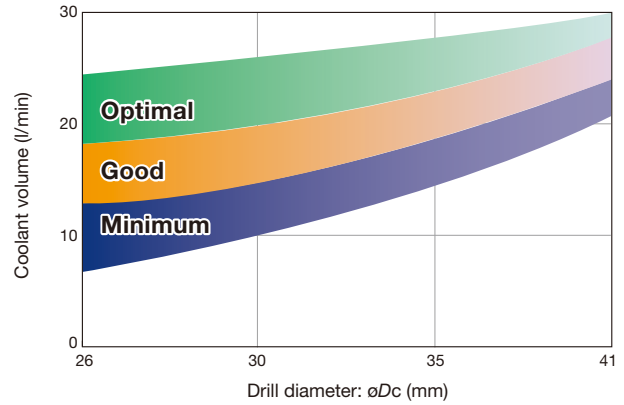
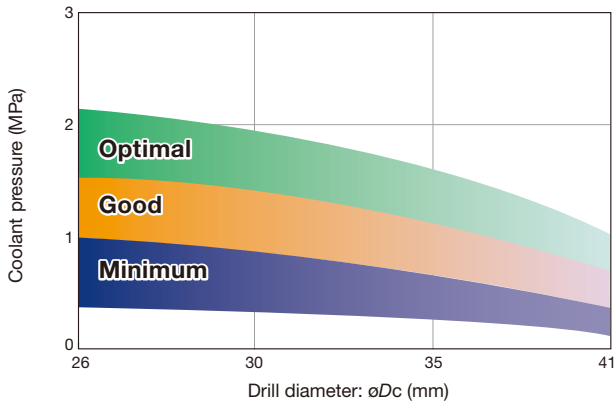

REQUIRED MACHINE POWER AND TORQUE

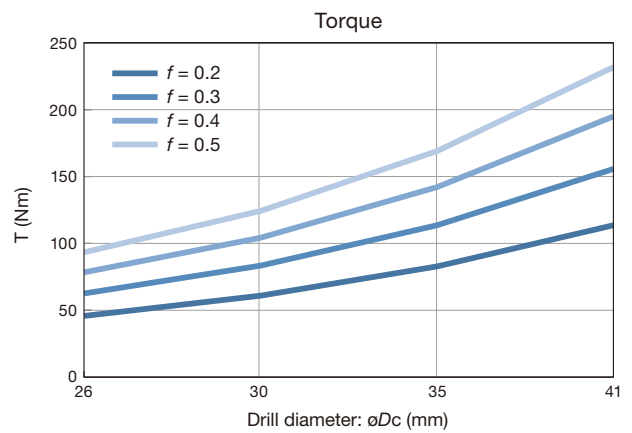
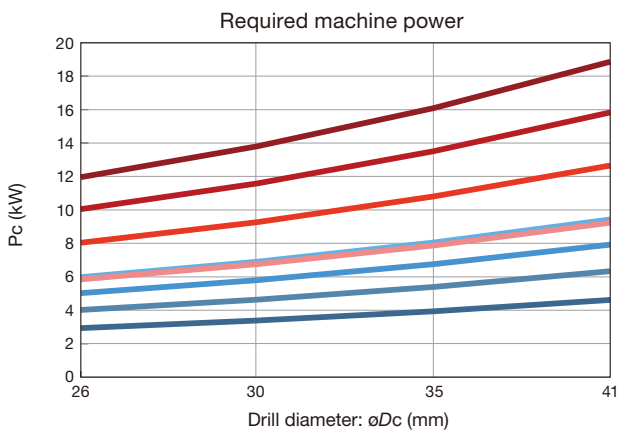

- $V_c = 50, f = 0.2$
- $V_c = 50, f = 0.3$
- $V_c = 50, f = 0.4$
- $V_c = 50, f = 0.5$
- $V_c = 100, f = 0.2$
- $V_c = 100, f = 0.3$
- $V_c = 100, f = 0.4$
- $V_c = 100, f = 0.5$

- Please access to "Tungaloy machining power" to calculate more detailed cutting forces.

<http://mpwr.imc-companies.com/machiningpwr/machiningpower.wgx?vwg-instance=3d4bfb46110a456b8d375e68942cd0a3&Home=tungaloy>



REGRINDING HOLDER

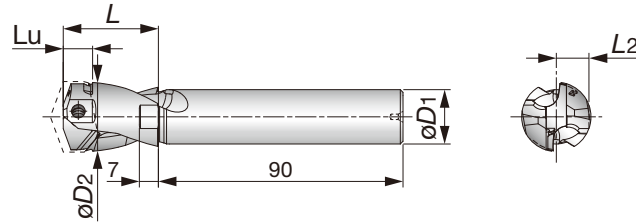

Designation	øD1	øD2	L	Lu	L2	Head
SMP260-279-GH	20	25.5	35	10.8	12	SMP260-SMP279
SMP280-299-GH	20	27.5	35	10.8	13	SMP280-SMP299
SMP300-319-GH	20	29.5	35	13	14	SMP300-SMP319
SMP320-349-GH	20	31.5	35	13	15	SMP320-SMP349
SMP350-379-GH	20	34.5	40	14.7	16.5	SMP350-SMP379
SMP380-410-GH	20	37.5	40	15.1	18	SMP380-SMP410

① Clamping

- Assemble the drill head on the regrinding holder or shortest standard holder (3xD)
- Set-up the drill head in the machine : Total run-out must be less than 0.02 mm

② Grinding the 1st clearance angle

- Set the drill for point angle (140°) and 1st clearance angle (8°)
- Keep the cutting edge in the horizontal plane

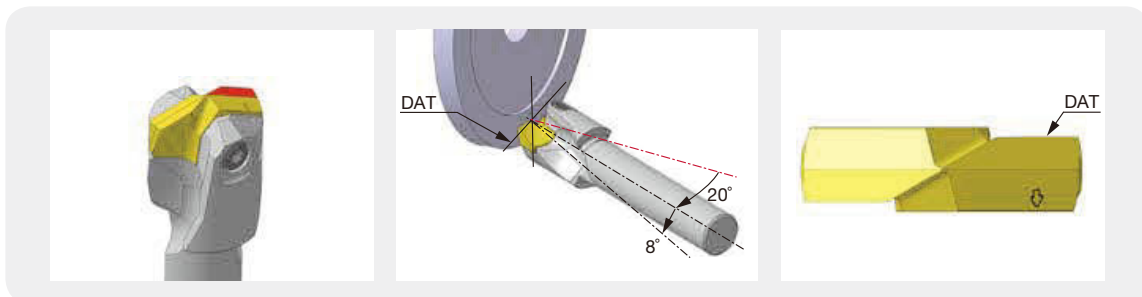

③ Grinding the 2nd clearance angle

- Set the drill for 2nd clearance angle (15°)

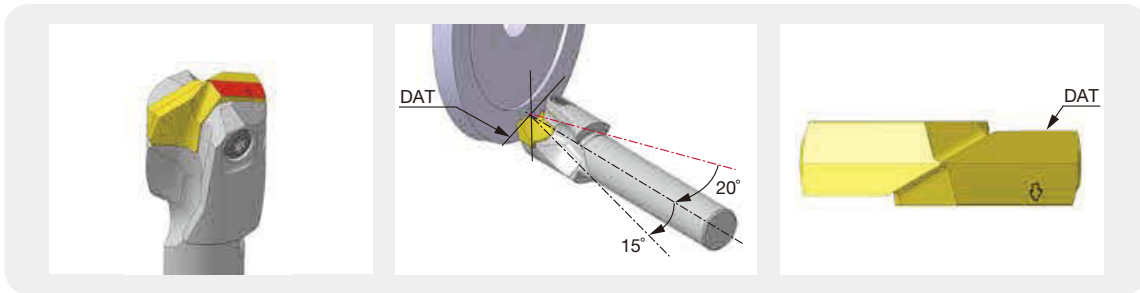

④ Grinding the chisel (Thinning)

- Set the drill for thinning angle (35°) with reference to drill axis and angle (30°) with reference to radial axis
- Keep the chisel thickness (0.14 - 0.20) and the thinning point must be over the center line

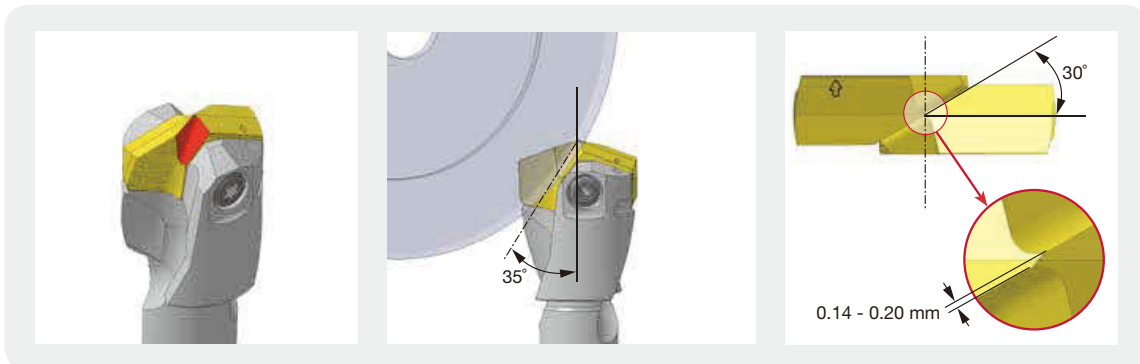

⑤ Edge preparation (Honing)

- Cutting edges should have honing by sand or brush (0.04 - 0.06 mm)
- Nega-land by diamond hand lapper is also available
- The width of honing must be uniform with good surface finish

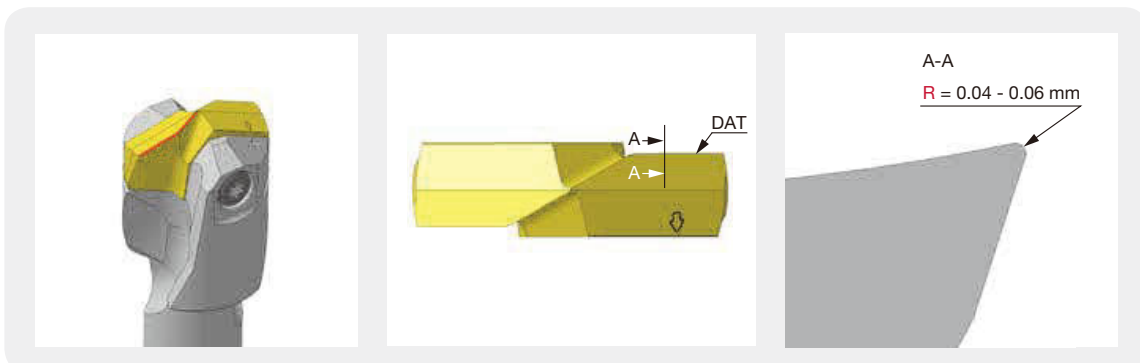

HOW TO CHANGE DRILL HEAD

To unclamp rotate the screw 3-5 times counter-clockwise.

No need to remove the screw from the body.



- Please change the screw to new one when the screw does not rotate smoothly

PRACTICAL EXAMPLES

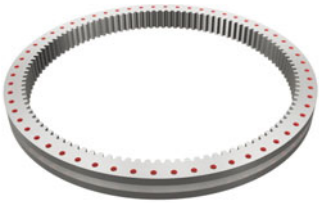
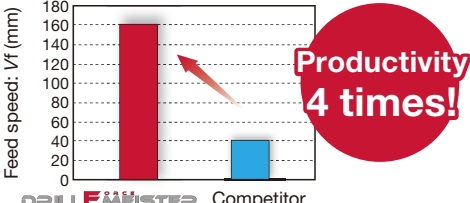
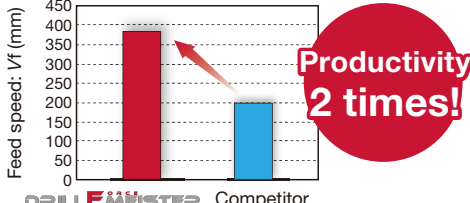
Workpiece type	Gate valve	Slewing ring	
Drill	TIS300F40-5	TIS330F40-5	
Head	SMP300	SMP331	
Grade	AH725	AH725	
Workpiece material	SUS304 / X5CrNi18-9	SCM440 / 42CrMo4	
	 M	 P	
Cutting conditions	Cutting speed: V_c (m/min)	60	100
	Feed : f (mm/rev)	0.25	0.4
	Feed speed : V_f (mm)	160	380
	Drilling depth : H (mm)	120	150
	Machine	Horizontal M/C	Vertical M/C
Results	 <p>Productivity 4 times!</p> <p>DrillForce-Meister provides 4 times productivity than HSS drill.</p>	 <p>Productivity 2 times!</p> <p>DrillForce-Meister provides 2 times productivity and more stable hole diameter compare with indexable drill.</p>	

Tungaloy Corporation (Head office)

11-1 Yoshima-Kogyodanchi
Iwaki-city, Fukushima, 970-1144 Japan
Phone: +81-246-36-8501
Fax: +81-246-36-8542
www.tungaloy.co.jp

Tungaloy America, Inc.

3726 N Ventura Drive
Arlington Heights, IL 60004, U.S.A.
Phone: +1-888-554-8394
Fax: +1-888-554-8392
www.tungaloyamerica.com

Tungaloy Canada

432 Elgin St. Unit 3
Brantford, Ontario N3S 7P7, Canada
Phone: +1-519-758-5779
Fax: +1-519-758-5791
www.tungaloy.co.jp/ca

Tungaloy de Mexico S.A.

C Los Arellano 113,
Parque Industrial Siglo XXI
Aguascalientes, AGS, Mexico 20290
Phone: +52-449-929-5410
Fax: +52-449-929-5411
www.tungaloy.co.jp/mx

Tungaloy do Brasil Ltda.

Avd. Independencia N4158 Residencial Flora
13280-000 Vinhedo, São Paulo, Brasil
Phone: +55-19-38262757
Fax: +55-19-38262757
www.tungaloy.com.br

Tungaloy Germany GmbH

An der Alten Ziegelei 1
D-40789 Monheim, Germany
Phone: +49-2173-90420-0
Fax: +49-2173-90420-19
www.tungaloy.de

Tungaloy France S.A.S.

ZA Courtaboeuf - Le Rio
1 rue de la Terre de feu
F-91952 Courtaboeuf Cedex, France
Phone: +33-1-6486-4300
Fax: +33-1-6907-7817
www.tungaloy.fr

Tungaloy Italia S.r.l.

Via E. Andolfato 10
I-20126 Milano, Italy
Phone: +39-02-252012-1
Fax: +39-02-252012-65
www.tungaloy.it

Tungaloy Czech s.r.o.

Turanka 115
CZ-627 00 Brno, Czech Republic
Phone: +420-532 123 391
Fax: +420-532 123 392
www.tungaloy.cz

Tungaloy Ibérica S.L.

C/Miquel Servet, 43B, Nau 7
Pol. Ind. Bufalvent
ES-08243 Manresa (BCN), Spain
Phone: +34 93 113 1360
Fax: +34 93 876 2798
www.tungaloy.es

Tungaloy Scandinavia AB

Bultgatan 38
442 40 Kungälv, Sweden
Phone: +46-462119200
www.tungaloy.se

Tungaloy Rus, LLC

36-D Harkovsky Lane
308009 Belgorod, Russia
Phone: +7 4722 24 00 07
Fax: +7 4722 24 00 08
www.tungaloy.co.jp/ru

Tungaloy East LLC

Stachek str., h.4, office 2, Ekaterinburg,
620017, Russia
Phone: +7-343-389-13-22
Fax: +7-343-278-94-35
www.tungaloy.co.jp/ru

Tungaloy Polska Sp. z o.o.

ul. Genewska 24
03-963 Warszawa, Poland
Phone: +48-22-617-0890
Fax: +48-22-617-0890
www.tungaloy.co.jp/pl

Tungaloy U.K. Ltd

The Technology Centre,
Wolverhampton Science Park
Glaisher Drive, Wolverhampton
West Midlands WV10 9RU, UK
Phone: +44 121 4000 231
Fax: +44 121 270 9694
www.tungaloy.co.jp/uk
salesinfo@tungaloyuk.co.uk

Tungaloy Hungary Kft

Erzsébet királyné útja 125
H-1142 Budapest, Hungary
Phone: +36 1 781-6846
Fax: +36 1 781-6866
www.tungaloy.co.jp/hu
info@tungaloytools.hu

Tungaloy Turkey

Dudullu.OSB 4. Cad No:4
34776 Umranıye Istanbul, TURKEY
Phone: +90 216 540 04 67
Fax: +90 216 540 04 87
www.tungaloy.com.tr
info@tungaloy.com.tr

Tungaloy Benelux b.v.

Tjalk 70
NL-2411 NZ Bodegraven, Netherlands
Phone: +31 172 630 420
Fax: +31 172 630 429
www.tungaloy-benelux.com

Tungaloy Croatia

Josipa Kozarca 4
10432 Bregana, Croatia
Phone: +385 1 3326 604
Fax: +385 1 3327 683
www.tungaloy.hr

Tungaloy Cutting Tool (Shanghai) Co.,Ltd.

Rm No 401 No.88 Zhabei
Jiangchang No.3 Rd
Shanghai 200436, China
Phone: +86-21-3632-1880
Fax: +86-21-3621-1918
www.tungaloy.co.jp/tcts

Tungaloy Cutting Tool (Thailand) Co.,Ltd.

Interlink tower 4th Fl.
1858/5-7 Bangna-Trad Road
km.5 Bangna, Bangna, Bangkok 10260
Thailand
Phone: +66-2-751-5711
Fax: +66-2-751-5715
www.tungaloy.co.th

Tungaloy Singapore (Pte.), Ltd.

62 Ubi Road 1, #06-11 Oxley BizHub 2
Singapore 408734
Phone: +65-6391-1833
Fax: +65-6299-4557
www.tungaloy.co.jp/tspl

Tungaloy Vietnam

Unit 18, 4th Fl. Saigon Centre Building
65 Le Loi Blvd.
Dist 1, Ho Chi Minh City, Vietnam
Phone: +84-8-3827-0201
Fax: +84-8-3827-0203
www.tungaloy.co.jp/tspl

Tungaloy India Pvt. Ltd.

Indiabulls Finance Centre,
Unit # 902-A, 9th Floor,
Tower 1, Senapati Bapat Marg,
Elphinstone Road (West),
Mumbai -400013, India
Phone: +91-22-6124-8804
Fax: +91-22-6124-8899
www.tungaloy.co.jp/in

Tungaloy Korea Co., Ltd

#1312, Byucksan Digital Valley 5-cha
Beotkkot-ro 244, Geumcheon-gu
153-788 Seoul, Korea
Phone: +82-2-2621-6161
Fax: +82-2-6393-8952
www.tungaloy.co.jp/kr

Tungaloy Malaysia Sdn Bhd

50 K-2, Kelana Mall, Jalan SS6/14
Kelana Jaya, 47301
Petaling Jaya, Selangor Darul Ehsan
Malaysia
Phone: +603-7805-3222
Fax: +603-7804-8563
www.tungaloy.com.my

Tungaloy Australia Pty Ltd

PO Box 2232, Rowville,
Victoria 3178, Australia
Phone: +61-3-9755-8147
Fax: +61-3-9755-6070
www.tungaloy.com.au

PT. Tungaloy Indonesia

Kompleks Grand Wisata Block AA-10 No.3-5
Cibitung
Bekasi 17510, Indonesia
Phone: +62-21-8261-5808
Fax: +62-21-8261-5809
www.tungaloy.co.jp/id



www.tungaloy.com

follow us at:

facebook.com/tungaloyjapan

twitter.com/tungaloyjapan

To see this product in action visit:

Tung-TV

www.youtube.com/tungaloycorporation

Distributed by:



DOWNLOAD
Dr. Carbide App



Available on the
App Store



GET IT ON
Google play



AS9100 Certified
78006
2015.11.04
ISO14001 Certified
EC97J1123
1997.11.26